

Service Schematics

NOKIA

7610

SUPERNOVA

Introduction

Important:

This document is intended for use by authorized service centers only.

“Service Schematics” was created with focus on customer care.
The purpose of this document is to provide further technical repair information for NOKIA mobile phones on Level 3/4 service activities.
It contains additional information such as e.g. “Component finder”.

Saving process time and improving the repair quality is the aim of this document.
It is to be used additionally to the service manual and other training or service information such as Service Bulletins.

While every endeavour has been made to ensure the accuracy of this document, some errors may exist. If the reader finds any errors, NOKIA should be notified in writing.

Please send E-Mail to: TrainingAndVendor.Development@nokia.com

RM-354



Table of contents

Frontpage	1
System & USB connector	2
Betty, AVilma, audio, SIM & battery	3
Camera	4
RAPS, MicroSD, Camera, UI	5
UI Interface	6
RF part	7
Component finder	8

Copyright © NOKIA

This material, including documentation and any related computer programs is protected by copyright, controlled by NOKIA. All rights are reserved. Copying, including reproducing, modifying, storing, adapting or translating any or all of this material requires the prior written consent of NOKIA. This material also contains confidential information, which may not be disclosed to others without the prior written consent of NOKIA.

B2B to Docking PWB

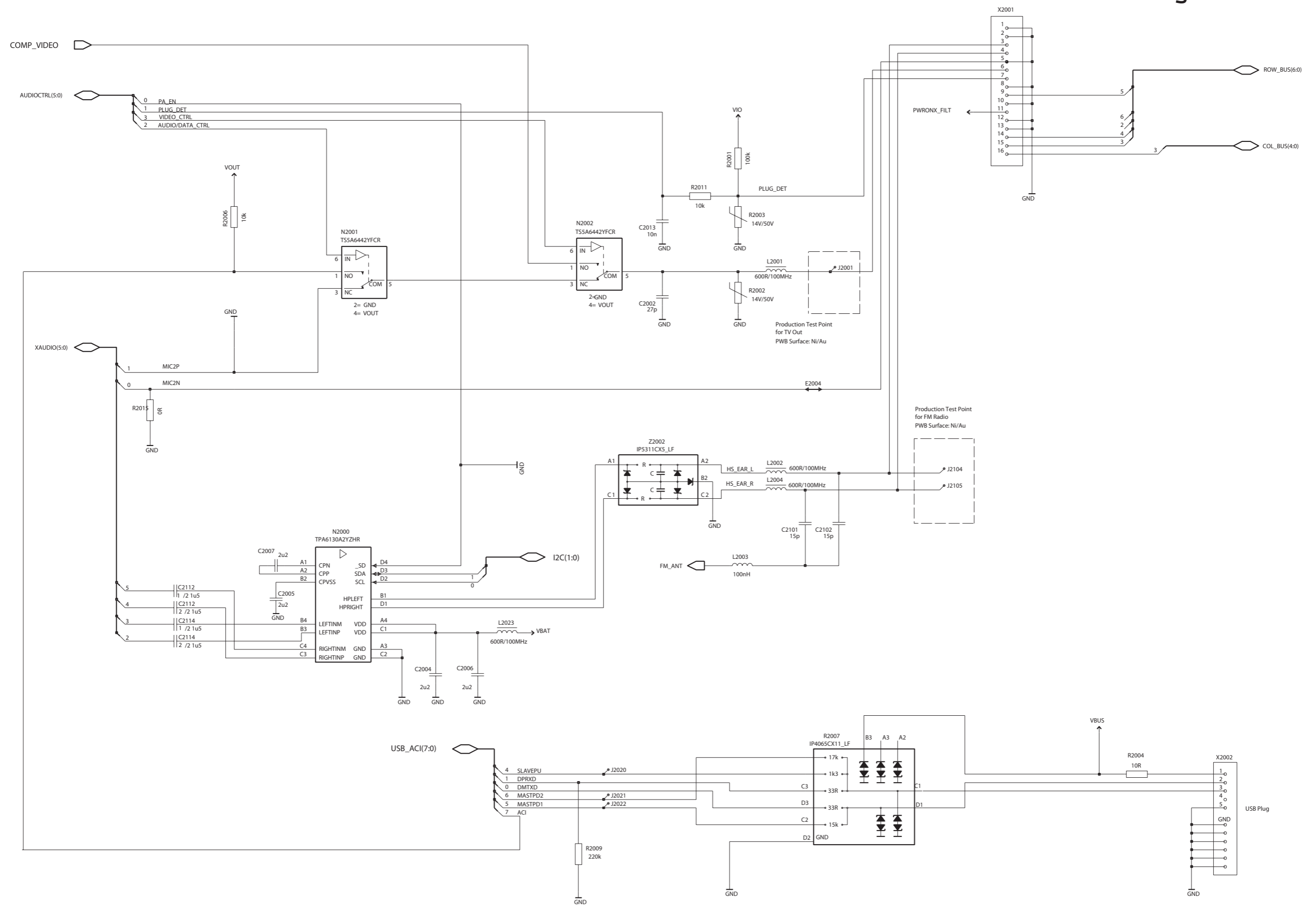

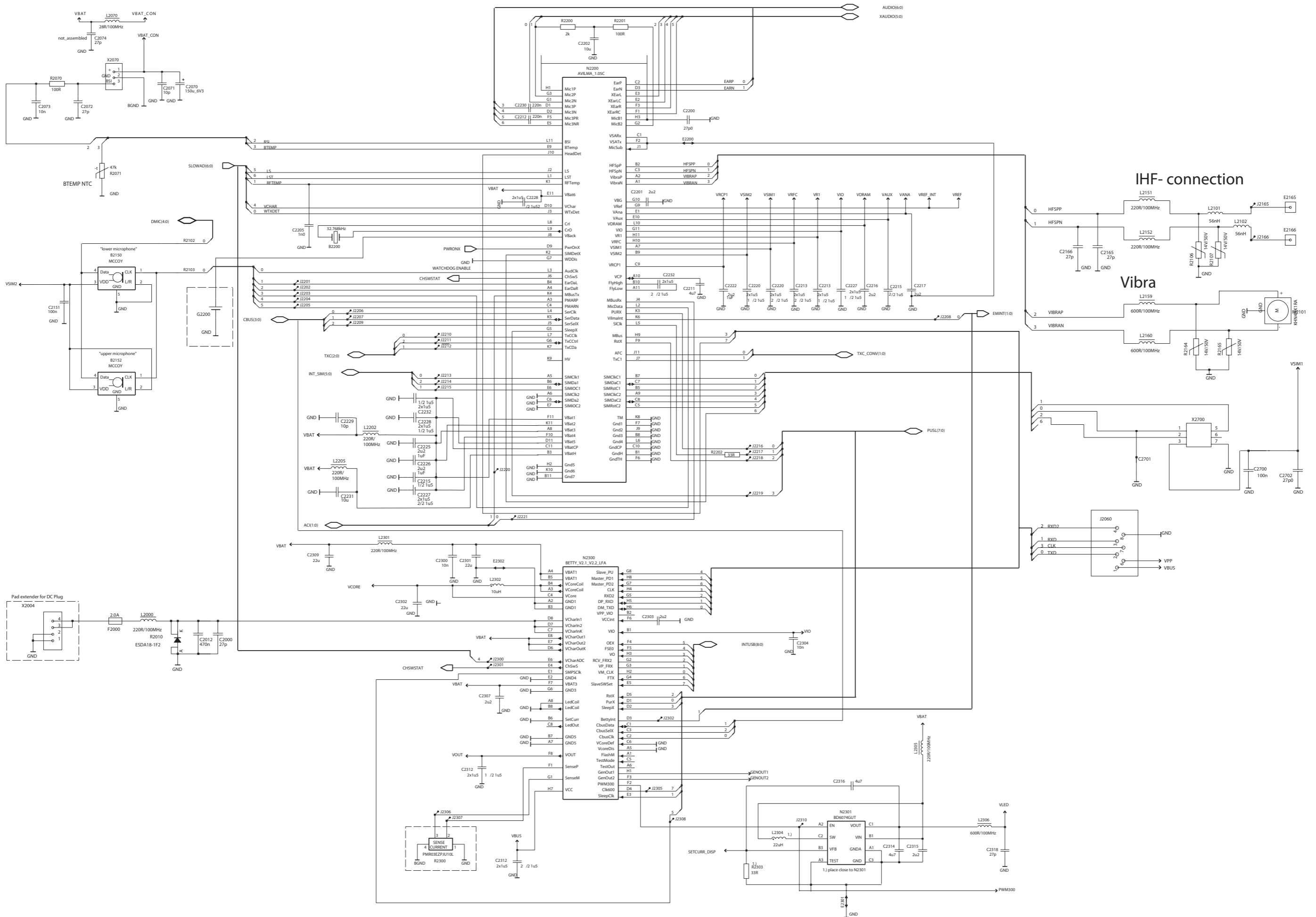

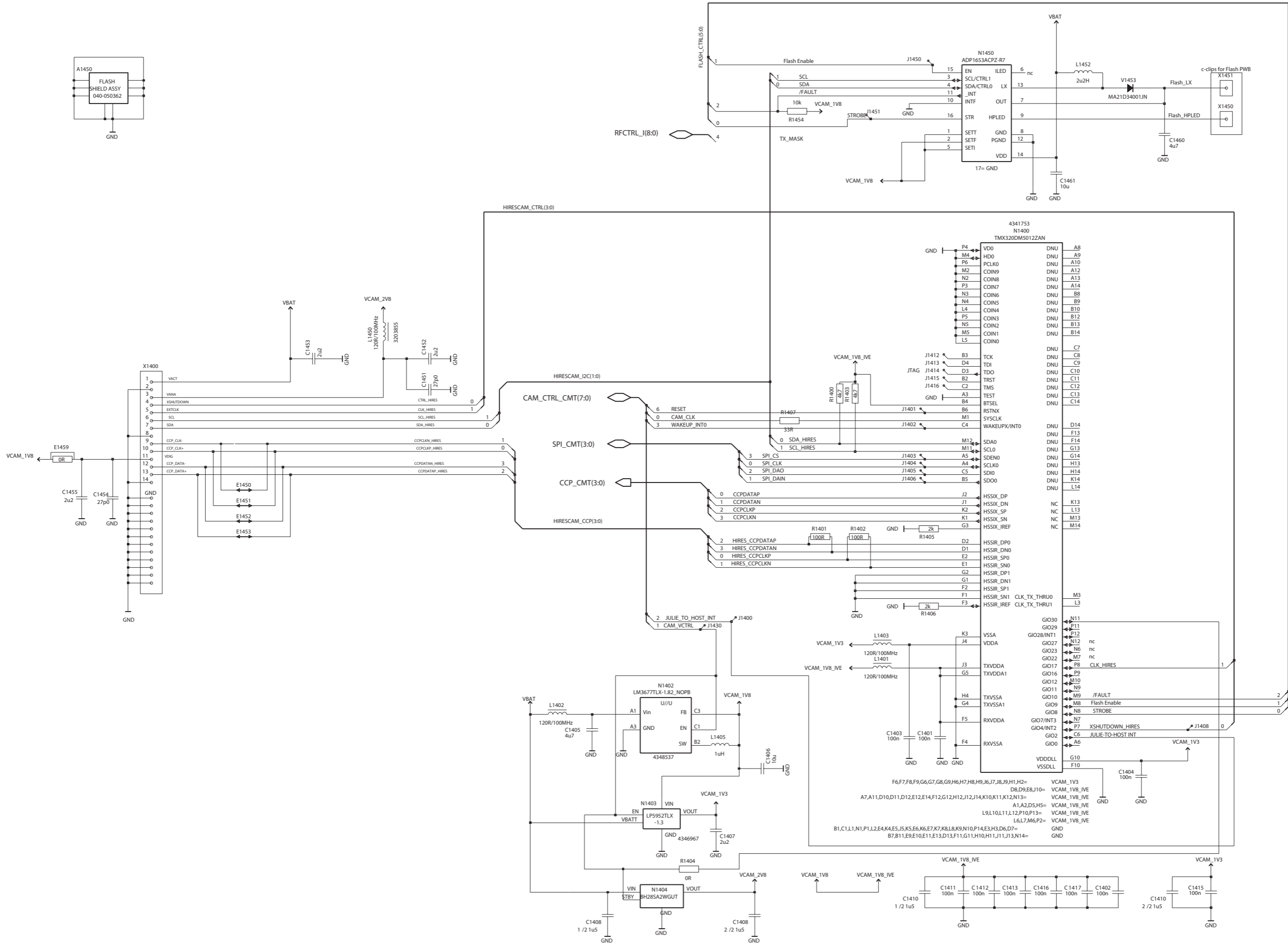

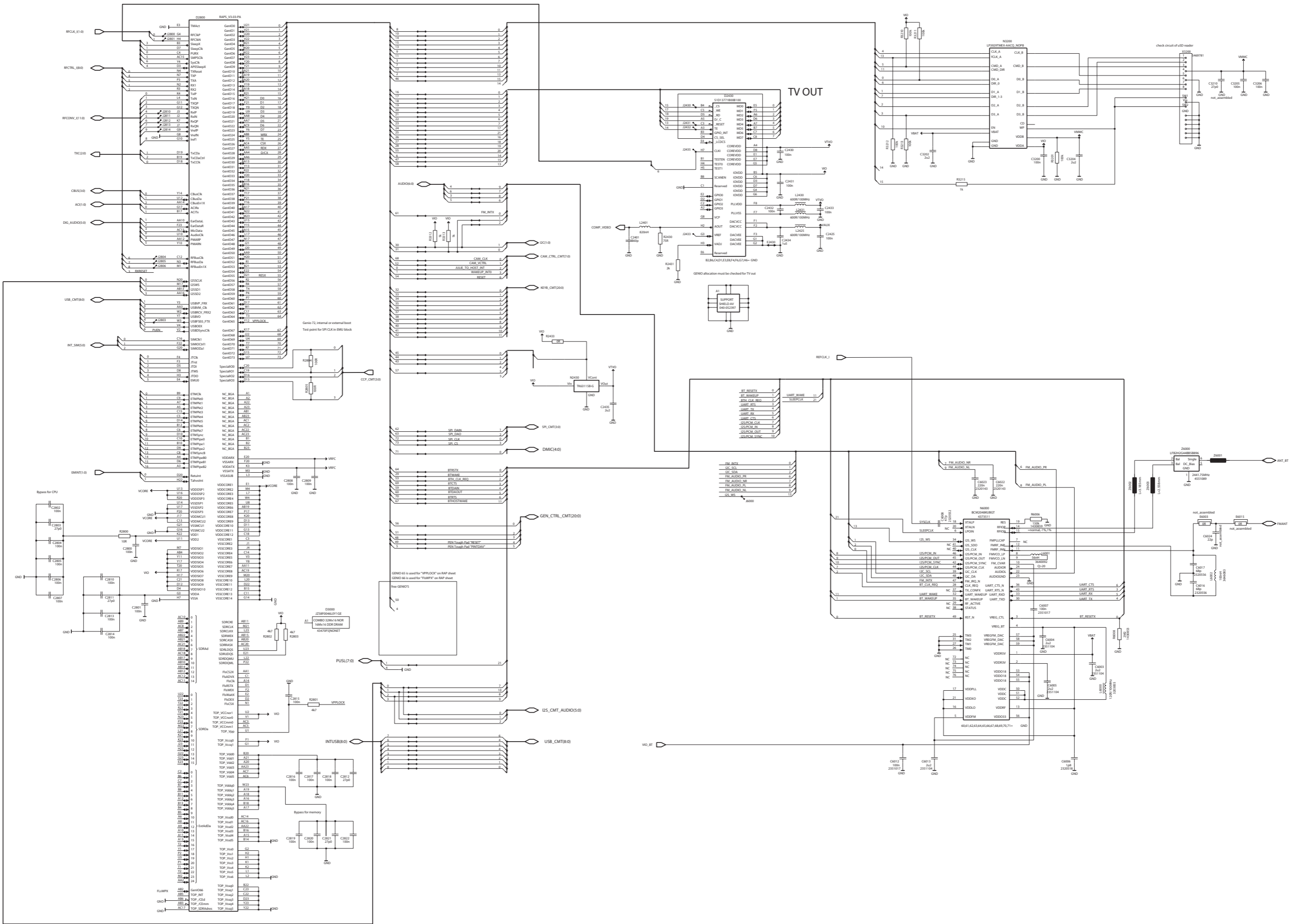

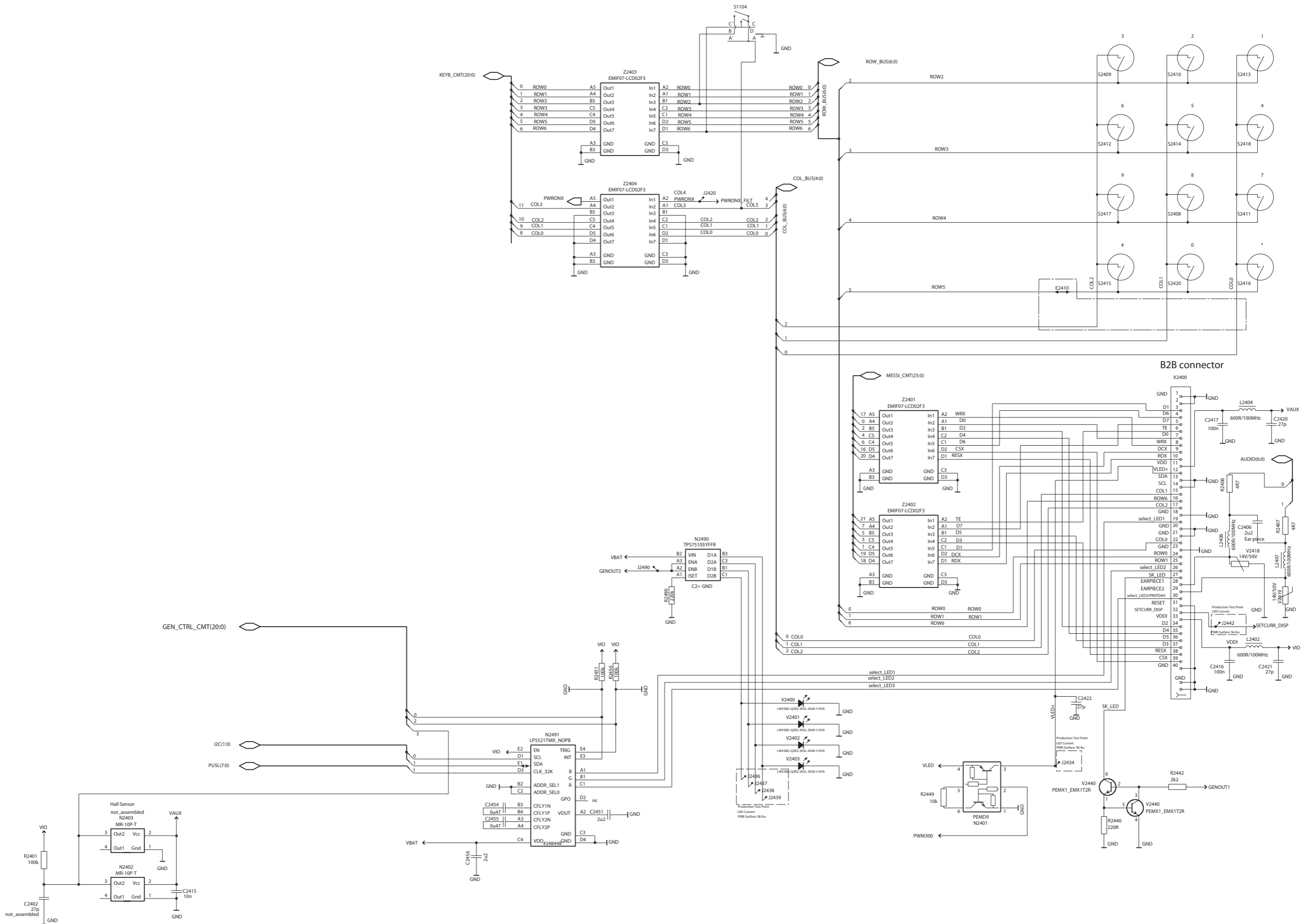

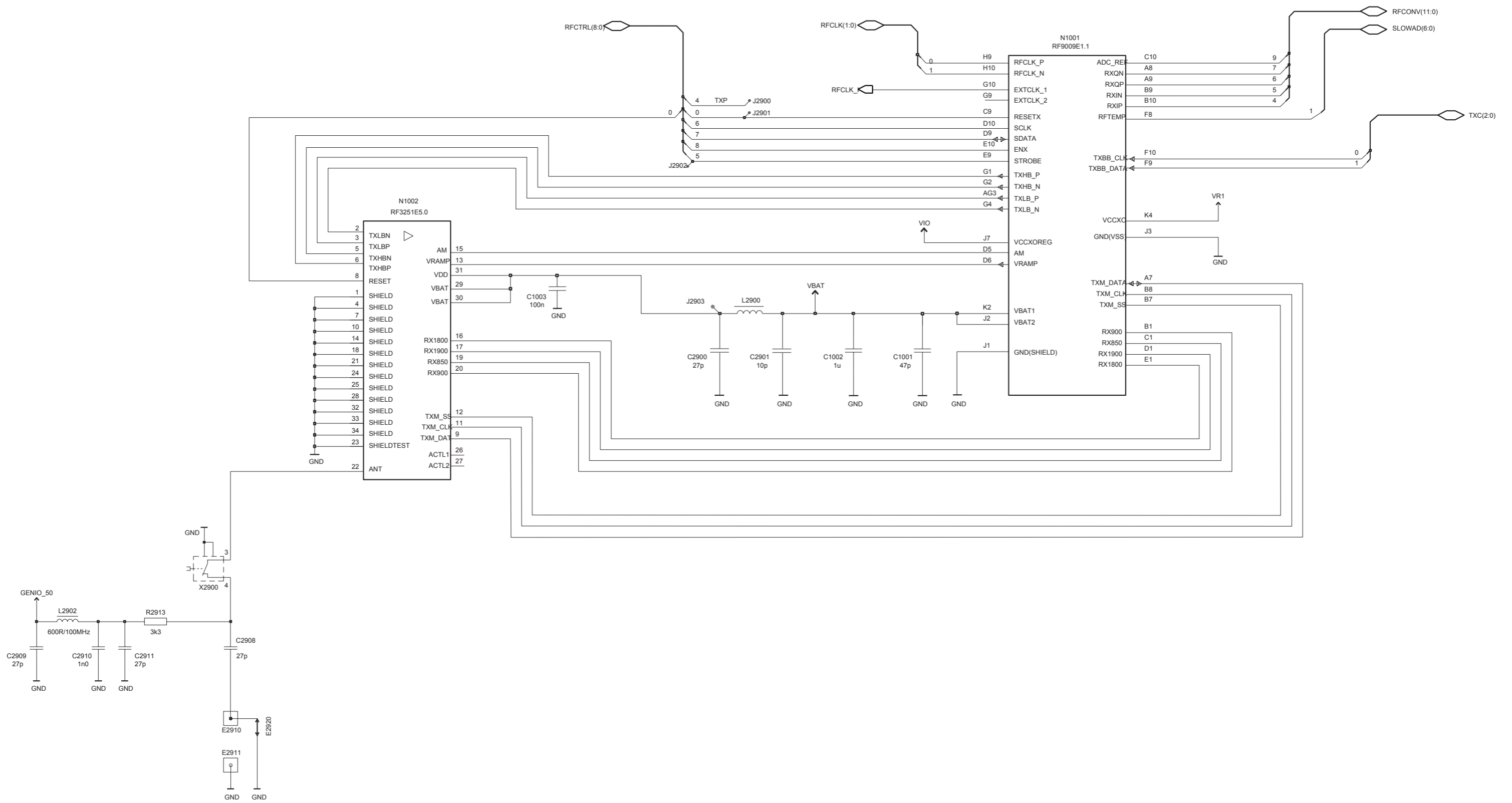

A	C2227	E4	C3202	H8	L2431	N2	R2401	H5	
A1450	P7	C2228	E4	C3204	I9	L6000	E4	R2406	M3
A2430	R3	C2229	E5	C3205	J8	L6001	D4	R2407	M3
B	C2230	C3	C3206	J8	L6002	C4	R2430	N1	
B2150	C9	C2231	G5	C3210	J8	L6020	D8	R2431	N1
B2152	F9	C2232	F5	C3216	H9	M	R2433	N1	
B2200	F3	C2300	H5	C6003	D4	M2101	R5	R2434	N2
C	C2301	H4	C6004	D4	N	R2440	E3		
C1001	E8	C2302	I5	C6005	D4	N1001	D6	R2442	E3
C1002	E7	C2303	G4	C6006	D3	N1002	D7	R2449	E2
C1003	E8	C2304	H4	C6007	D4	N1400	N4	R2450	D2
C1401	O5	C2307	H5	C6008	D3	N1402	N5	R2451	D2
C1402	O4	C2309	H5	C6012	E4	N1403	N5	R2490	C2
C1403	O5	C2312	G5	C6013	D3	N1404	R3	R2800	I6
C1404	N3	C2314	F3	C6016	C4	N1450	Q7	R2801	I7
C1405	N5	C2315	G3	C6017	C4	N2000	R2	R2802	I7
C1406	M5	C2316	F2	C6020	C8	N2001	R3	R2803	I6
C1407	N5	C2318	E2	C6022	E3	N2002	R3	R2804	I5
C1408	Q3	C2401	O1	C6023	C3	N2200	F4	R2805	H5
C1410	O5	C2402	H5	C6024	C4	N2300	H4	R3201	I9
C1411	N5	C2406	M3	D	N2301	F2	R3210	I8	
C1412	O3	C2415	F5	D2430	O2	N2401	E2	R3211	I8
C1413	O5	C2416	L1	D2800	H7	N2402	G5	R3212	H8
C1415	O5	C2417	M2	D3000	H7	N2403	F5	R3213	H8
C1416	N3	C2420	M2	E	N2430	N2	R3215	H8	
C1417	N3	C2421	M1	E2165	E1	N2490	C2	R3312	D3
C1451	Q7	C2422	K1	E2166	C1	N2491	D3	R3313	D3
C1452	Q7	C2425	O2	E2910	B6	N3200	I8	R6006	D3
C1453	P6	C2430	O3	E2911	B7	N6000	D4	R6008	C3
C1454	Q3	C2431	M2	E6000	D9	R	S		
C1455	Q3	C2432	N2	F	R1400	O3	S1104	F1	
C1460	Q7	C2433	N2	F2000	R8	R1401	N4	V	
C1461	P8	C2434	O2	G	R1402	N4	V1453	P7	
C2000	Q7	C2435	N2	G2200	I1	R1403	O3	V2400	E4
C2002	S3	C2451	D3	L	R1404	R3	V2401	E6	
C2004	R3	C2454	D2	L1401	O5	R1405	N5	V2402	C6
C2005	R1	C2455	D2	L1402	N5	R1406	N5	V2403	C4
C2006	R3	C2456	D2	L1403	O5	R1407	O4	V2418	M2
C2007	R3	C2461	D3	L1405	M5	R1410	R3	V2419	M2
C2012	R7	C2463	D2	L1450	R7	R1454	Q7	V2440	E3
C2013	Q1	C2700	J8	L1452	P7	R2001	Q1	X	
C2014	R3	C2701	J8	L2000	R8	R2002	S3	X1400	Q5
C2070	E9	C2702	J8	L2001	S2	R2003	Q1	X1450	Q6
C2071	E8	C2800	I6	L2002	R2	R2004	P6	X1451	Q6
C2072	F7	C2801	H5	L2003	S2	R2005	R2	X2001	P3
C2073	F5	C2802	I8	L2004	R2	R2006	R3	X2002	P9
C2074	F9	C2803	G7	L2023	R3	R2007	P6	X2004	S7
C2101	S2	C2804	G8	L2070	F8	R2009	P6	X2060	J1
C2102	S2	C2805	I6	L2101	D1	R2010	R7	X2070	F7
C2112	Q2	C2806	G6	L2102	C1	R2011	Q1	X2400	L2
C2114	Q3	C2807	I5	L2151	D1	R2014	G4	X2700	K7
C2151	F9	C2808	G6	L2152	D1	R2015	G4	X2900	B7
C2165	D1	C2809	I6	L2159	R3	R2070	F5	X3200	N7
C2166	D1	C2810	I6	L2160	S3	R2071	Q1	Z	
C2200	G3	C2811	G7	L2202	E5	R2101	F9	Z1450	Q4
C2201	F3	C2812	I6	L2205	G5	R2102	E9	Z1451	Q4
C2202	G3	C2813	H5	L2301	I5	R2103	E9	Z2002	R2
C2205	G3	C2814	F5	L2302	I4	R2106	D2	Z2401	M2
C2211	F5	C2815	G7	L2304	G2	R2107	C1	Z2402	N2
C2212	E3	C2816	I7	L2305	E3	R2164	R3	Z2403	M4
C2213	E3	C2817	H8	L2306	E2	R2165	S3	Z2404	M4
C2215	E4	C2818	I5	L2401	O1	R2200	G3	Z6000	C4
C2216	E3	C2819	F6	L2402	L1	R2201	G3		
C2217	G4	C2820	G6	L2404	M2	R2202	E3		
C2220	F5	C2821	I6	L2406	M2	R2250	G3		
C2222	F5	C2822	I7	L2407	M2	R2251	G3		
C2225	F5	C2900	D8	L2425	O2	R2300	E7		
C2226	E3	C3200	I8	L2430	N2	R2303	F2		

